

Varenummer: 0125103
 Beskrivelse: Seeger låsering SP110
 Fjederstål

Mål

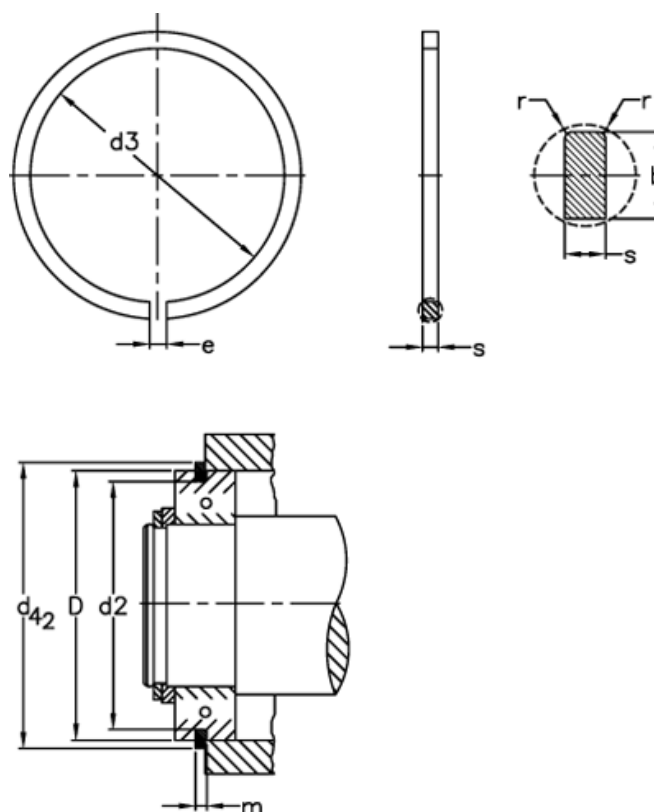

b	= 4.85	FRg kN	= 10.40	tol	= -0.15
Betegnelse	= SP 110	FR kN	= 71.2	tol	= -0.1
D	= 110	g	= 3.5	tol	= -0.50
d2	= 106.81	K kN-mm	= 142.0	tol	= 0.3
d3	= 105.2	m	= 2.70	tol	= 1.0
d42	= 116.6	n abl x 1000	= 1.0	vægt kg/1000	= 32.8
e	= 5	r min	= 0.7		
FN kN	= 90.7	s	= 2.46		